

English

COMPUTER TABLE

ASSEMBLY INSTRUCTION

Thanks for purchasing one of our products, please read carefully the assembly instructions before the installation (Attention: Do not tighten the screws before all screws are in place).

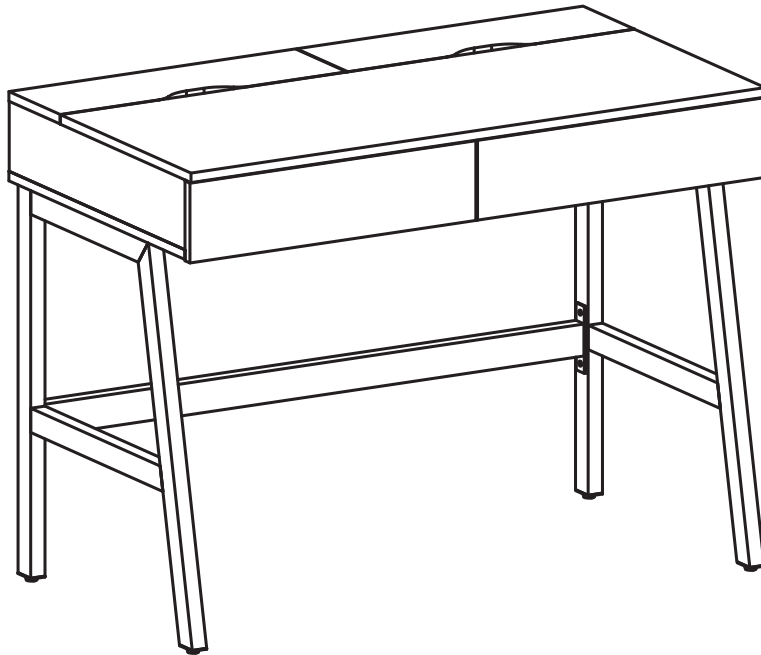

**TWO PEOPLE
REQUIRED**

CT-3534F

General Care:

-Keep your furniture out direct sunlight-Use desk pads and coasters to protect the surface from dents,scratches,and moisture from hot or cold liquids.

Cleaning:





-For cleaning, wipe the surface with a damp (not wet) cloth or wipe dry with a clean lint free cotton cloth.
-Window cleaning liquid or a similar cleaning liquid can be used to clean glass surface.

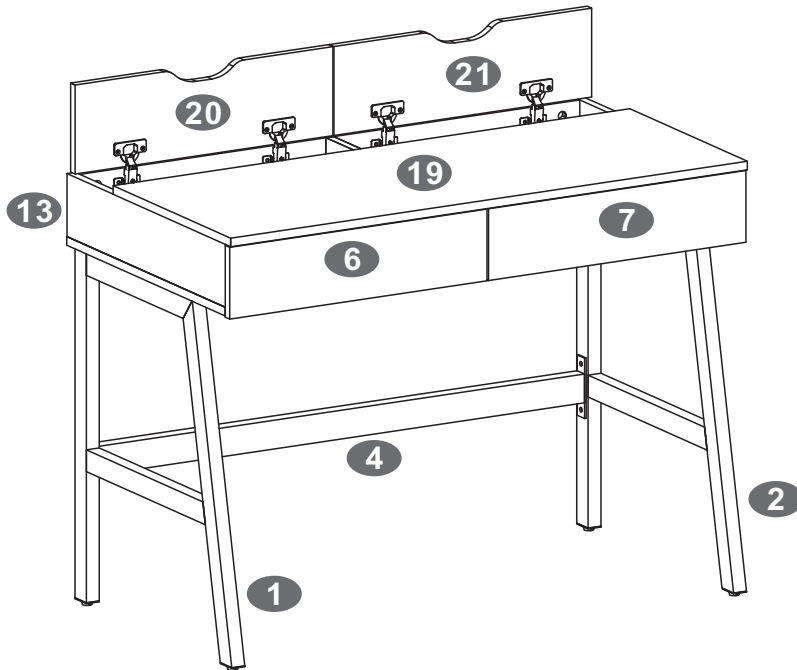

▪PARTS LIST

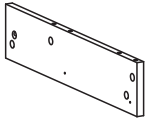
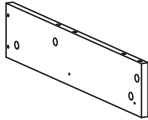
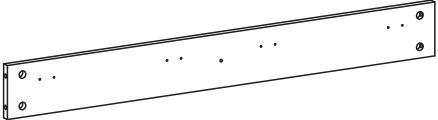
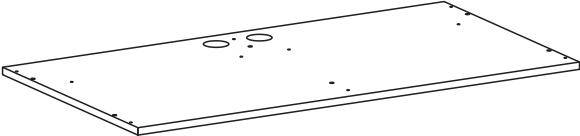

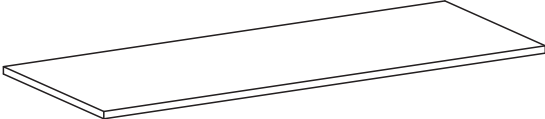
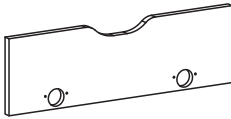
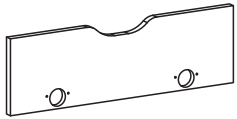
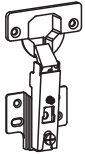
 X1	 X1	 X1		
		 X1		
 X4	 X1	 X1	 X2	 X2
 X2	 X2	 X2	 X1	

 <p>14</p> <p>X1</p>	 <p>15</p> <p>X1</p>	 <p>16</p> <p>X1</p>	
 <p>17</p> <p>X1</p>		 <p>18</p> <p>X2</p>	
 <p>19</p> <p>X1</p>	 <p>20</p> <p>X1</p>	 <p>21</p> <p>X1</p>	
 <p>22</p> <p>X4</p>	 <p>23</p> <p>X2</p>	 <p>24</p> <p>X4</p>	

SCREWS LIST

PART	QTY.	ITEM		PART	QTY.	ITEM	
A	25	6X40 MM		G	24	4X16 MM	
B	24	3X15 MM		H	12	8X30 MM	
C	8	4X35 MM		I	25	Φ 15 MM	
D	12	6X15 MM			1		
E	4	6X50 MM					
F	2	6X35 MM					

6X40MM BOLT INSTALLATION AS BELOW:

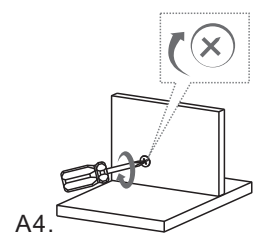
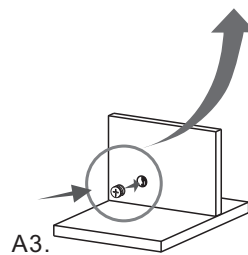
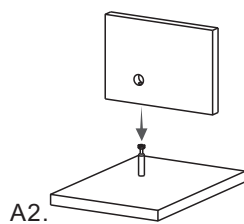
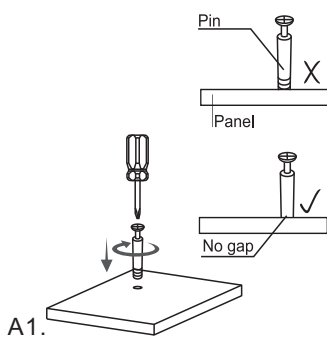
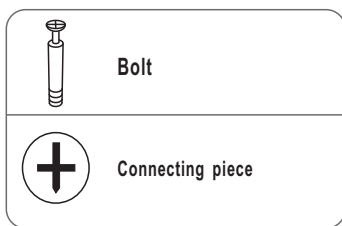

ASSEMBLY STEPS:

0 1 2 3 4 5 6 7 8 9 10 11 12 13 14 15 16 17 18 19 20 21 22 23 24

1

8 9 24

- SCREWS
B 3X15 MM
 x4

2

8 9 11 C

- SCREWS
C 4X35 MM
 x4

3

8 9 10 24 X2 6 OR 7

- SCREWS
D 6X15 MM
 x2

24

4

Repeat steps 1 to 4 to install the other drawer

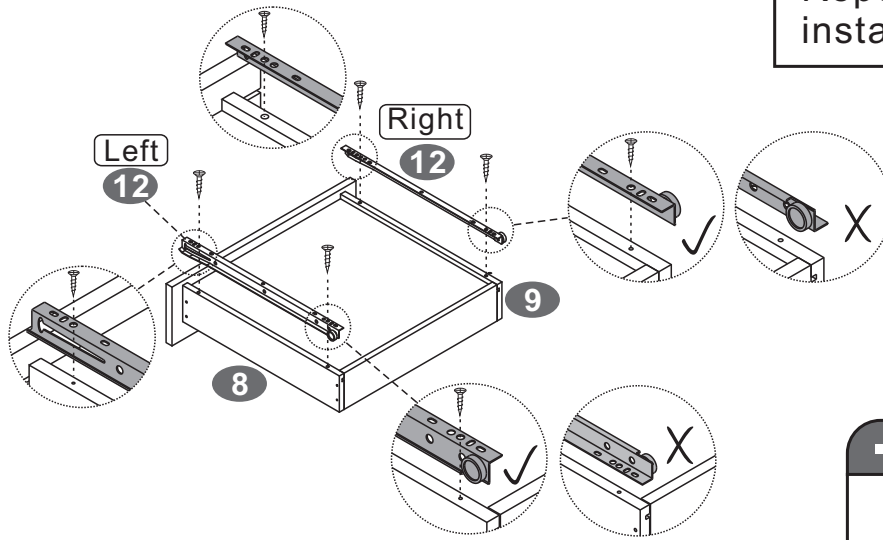

- SCREWS

B 3X15 MM

 x4



5

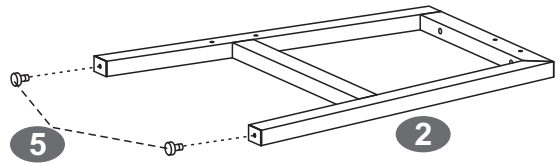
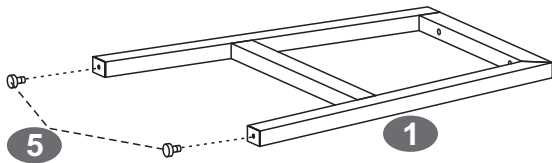

6

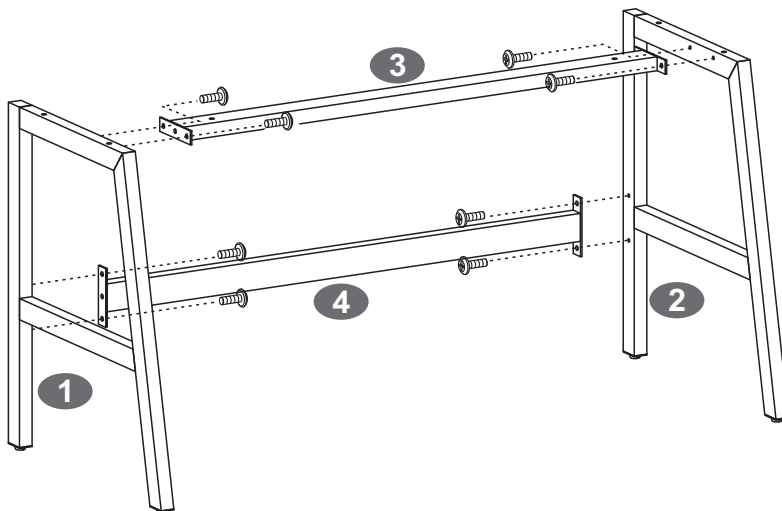

- SCREWS

D 6X15 MM

 x8



7

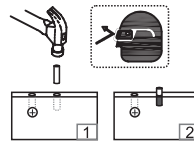
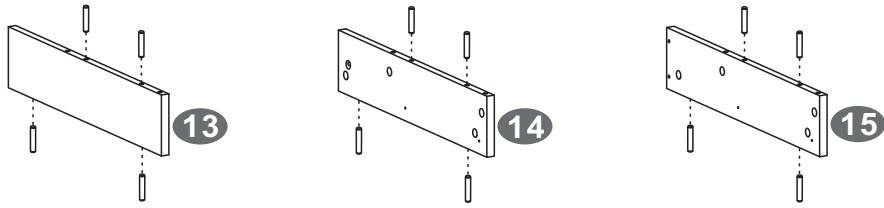

- SCREWS

H 8X30 MM
x12



8

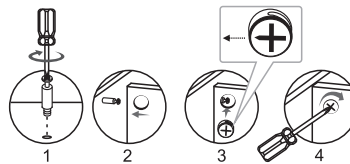
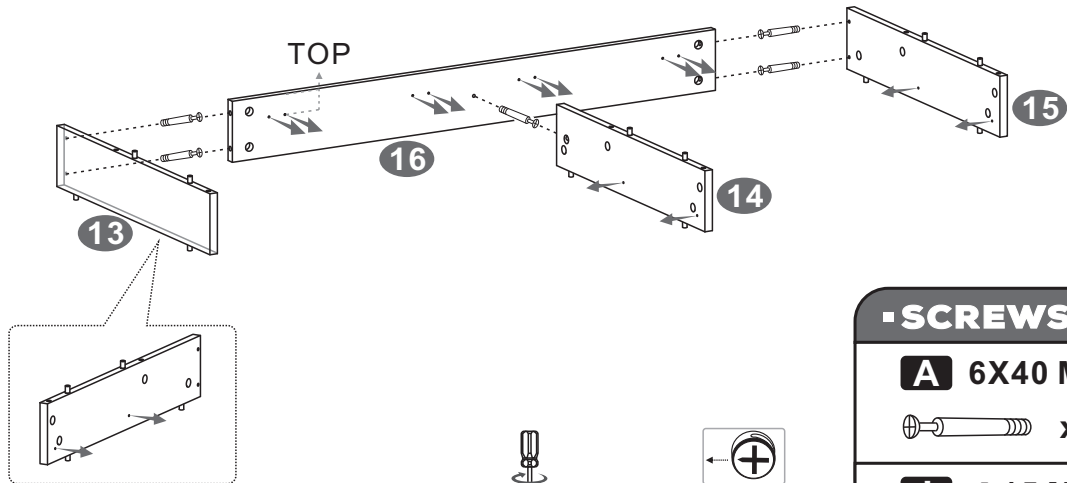

- SCREWS

A 6X40 MM
x5

I Φ 15 MM
x5



9

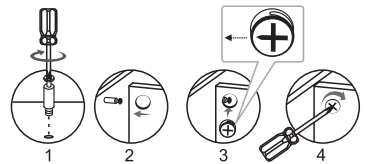
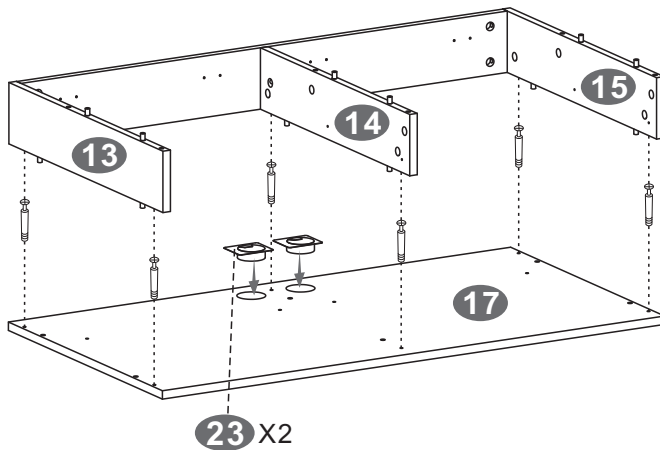

- SCREWS

A 6X40 MM
x6



I Φ 15 MM
x6

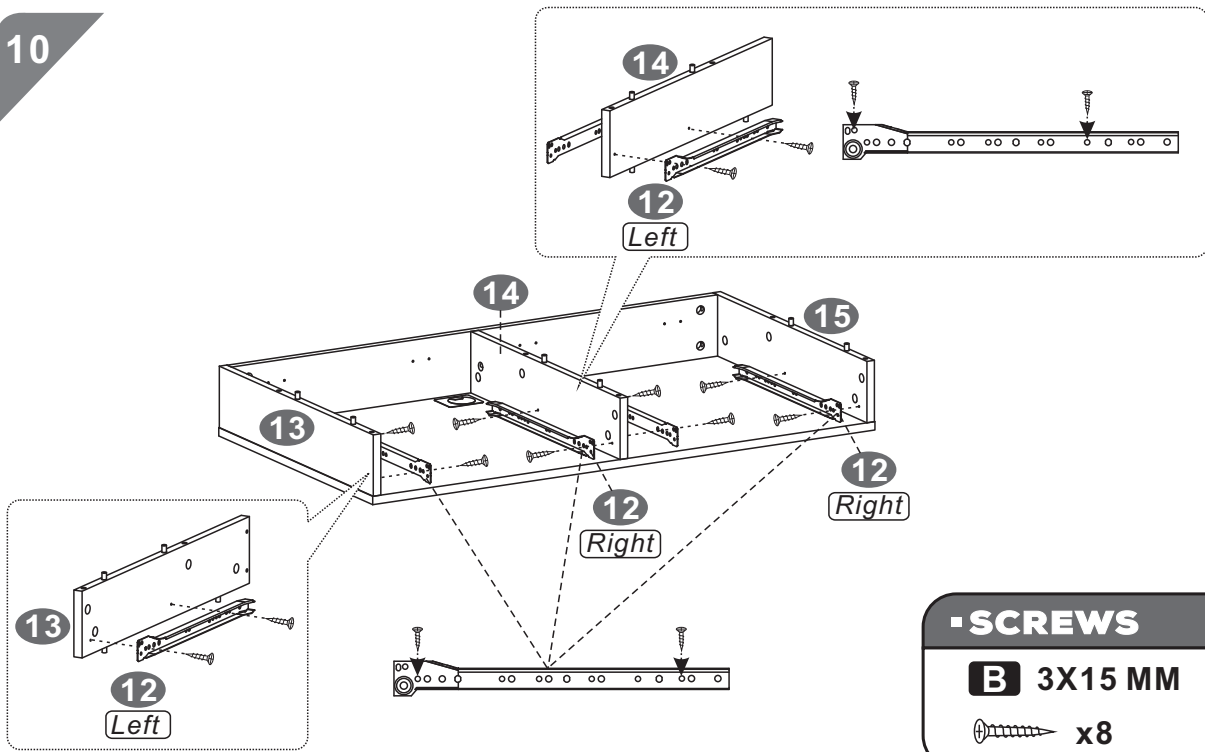

10





-SCREWS

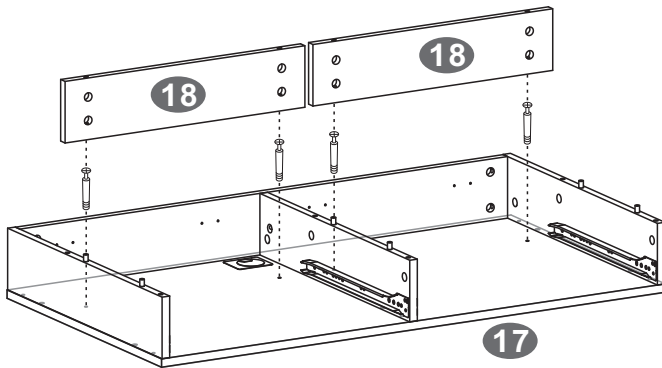

B 3X15 MM  **x8** 

11



-SCREWS

A 6X40 MM  **x4** 

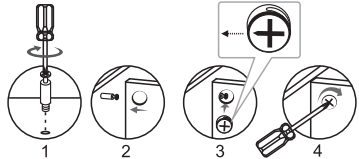

I Φ 15 MM  **x4** 



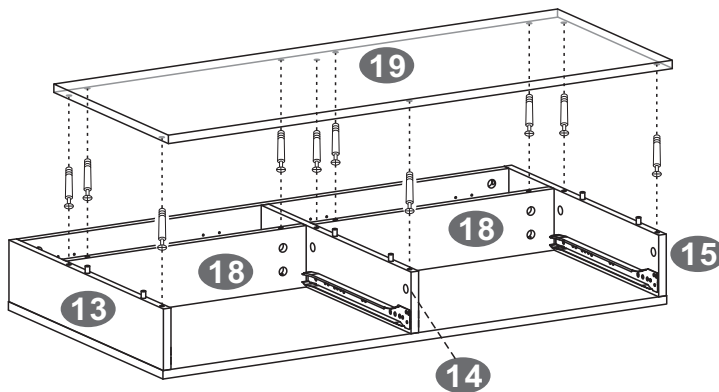

12



-SCREWS

A 6X40 MM  **x10** 

I Φ 15 MM  **x10** 

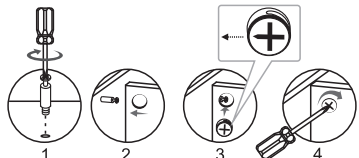

13

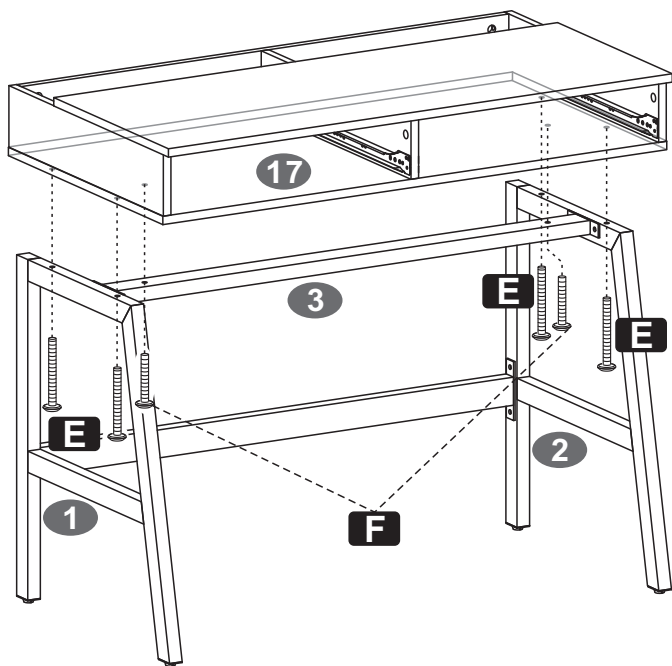

- SCREWS

F 6X35 MM

 x2

E 6X50 MM

 x4



14

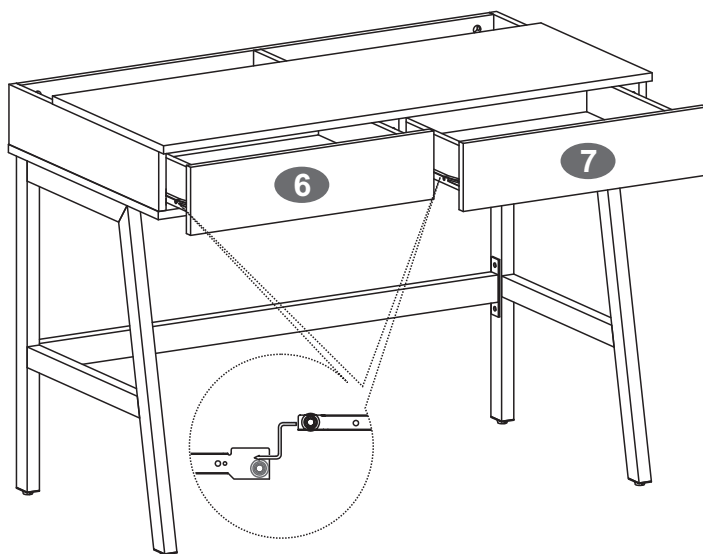

15

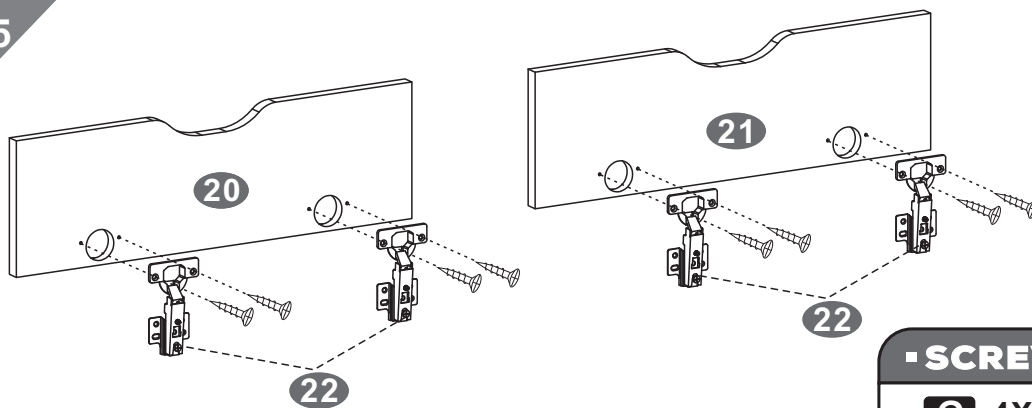

- SCREWS

G 4X16 MM

 x8



16

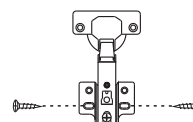
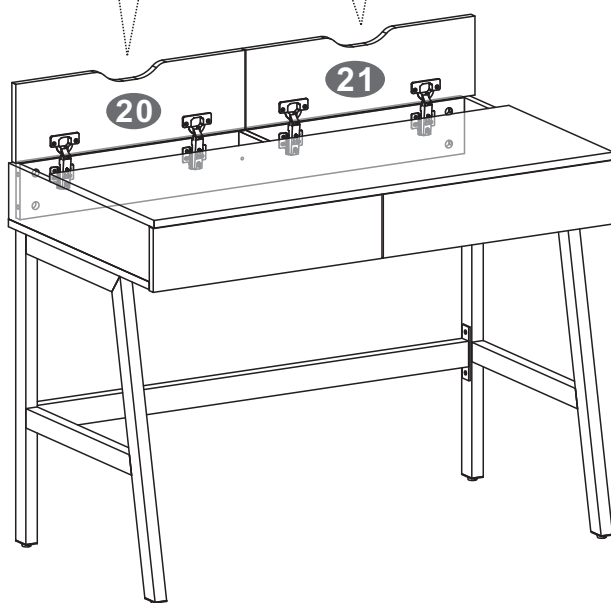
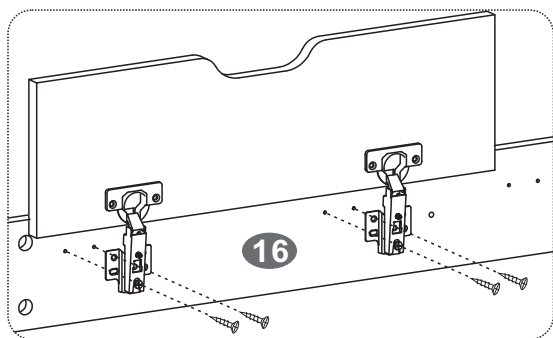

OR

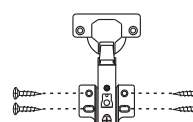

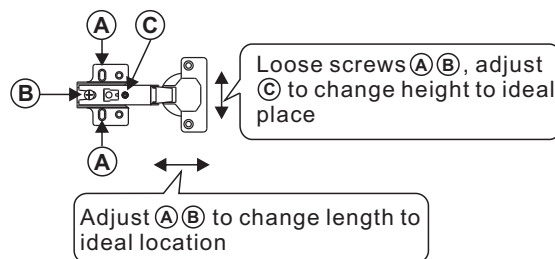

if necessary, fix 4 screws



-SCREWS

G 4X16 MM

 **x16**



17

